

To meet the latest production challenges, you need to execute workflows faster and more securely, while producers and finance teams need your work to be more cost-efficient. The flexibility and massive capacity of the world's fastest Thunderbolt RAID makes Pro Data the perfect all-in-one storage solution for film and television production. End-to-end XTS-AES-256 encryption and a Secure Enclave for encryption keys protect your valuable digital assets from unauthorized access. Hardware-accelerated RAID-6 protects against data loss up to SSD failures. Your computer's resources remain dedicated to powering through the most demanding workflows. Below are examples of deploying Pro Data for film & TV production.

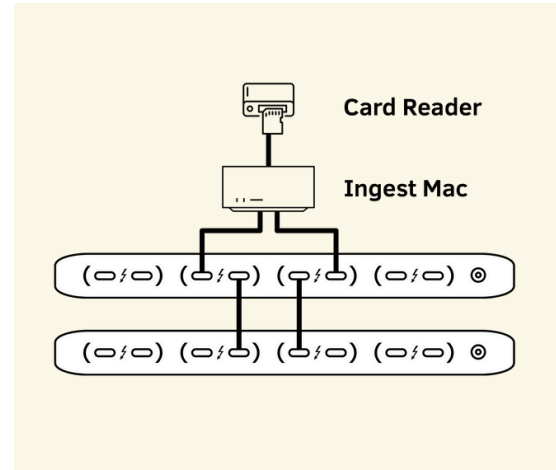

## On-Set Ingest and Shuttle

Pro Data fits easily on the most crowded DIT cart to handle all of your on-set data workflow jobs. Ingest hires footage at full speed from multiple sources simultaneously with whisper-quiet operation and end-to-end encryption. Assemble rough cuts and temp color grades without proxies, all on-set and in real-time.



## Near-Set Editing

Up to four editors, VFX artists, and assistants collaborate seamlessly without recabling, using Storage Handoff to exchange storage containers with a simple menu selection. High performance workstations employ breakthrough Thunderbolt Multipathing to accelerate storage access. Add more Pro Datas for even larger team collaboration, capacity, or performance.

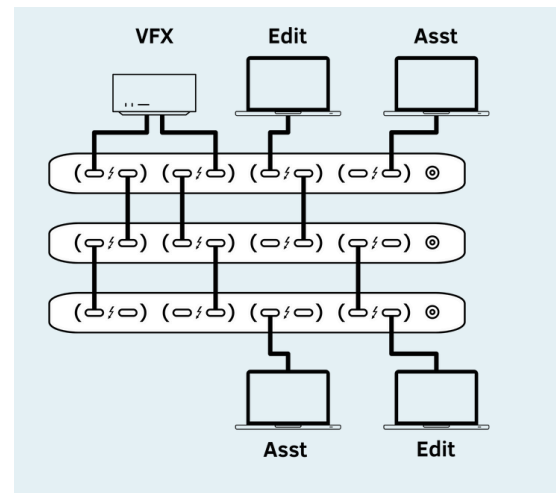

## Post-Production

Editors, colorists, and VFX artists create at the speed of thought using full-resolution assets instead of waiting for proxies to render or files, and without the bottlenecks of an overloaded network or company SAN. Maintain critical data integration with RAID-6 protection, and expand storage dynamically for larger team projects.

